

Design of a Direct Gain Passive Solar Heating System

Md. Tanbiruj Jaman, Md. Masudur Rahman and A.N.M. Mizanur Rahman

Mechanical Engineering Department

Khulna University of Engineering and Technology

Khulna, Bangladesh

Abstract

The solar energy that falls naturally on a building can be used to heat the building without special devices to capture or collect sunlight in direct gain passive solar system. Passive solar heating makes use of large sun-facing windows (south-facing in the Northern Hemisphere) and building materials. A well-insulated building with such construction features can trap the sun's energy and reduce heating bills as much as 50 percent. Passive solar designs also include natural ventilation for cooling. Shading and window overhangs also reduce summer heat while permitting winter sun. In this paper, the heat energy obtained from solar energy is stored by thermal mass floor which is used to maintain comfortable higher temperature inside the room in day time as well as in the night. The thermal mass floor was made of stone chips. The overhang was also designed in simple, new, and effective way to reduce over heating during summer. The low cost materials used for the study in order to focus on low cost construction with comfortable result.

Keywords

Passive Solar System, Direct Gain, Determinants of Design

Nomenclature

U_L = Loss coefficient

F_{r-s} = Receiver Radiation View Factor

\bar{F}_c = an energy-weighted control function

$(\tau\alpha)$ = Product of transmittance and absorptance

\bar{H} = Daily average total radiation for the month

\bar{H}_b = Daily average beam radiation for the month

\bar{H}_d = Daily average diffuse radiation for the month
= Ground reflectance

F_I = A special control function

\bar{T}_r = Temperature inside the room, °C

\bar{T}_a = Ambient temperature, °C

\bar{f}_i = Monthly mean fraction of vertical receiver area receiving beam radiation as a function of relative overhang dimensions

\bar{R}_b = Ratio of the average daily beam radiation on the tilted surface to that on a horizontal surface

δ = Declination of sun

ϕ = Latitude of sun

A_r = Aperture area

\bar{S} = Average energy gain per unit area

1. Introduction

Solar energy is referred as energy contained in the rays of sun. Solar energy is available, only during day time and if it needs during night then some reservoir of energy should be used. At present harnessing, storage and use of solar energy is becoming more effective because of scarcity of available conventional energy (coal, oil, gas etc). Passive solar gain heating system is an important term in solar energy technology.

A passive solar building is one that derives a substantial fraction of its heat from the sun using only natural processes to provide the necessary energy flows. Thermal conduction, free convection, and radiation transport therefore replace the pumps, blowers, and controllers associated with active solar heating systems. The elements of a passive solar heating system tend to be closely integrated with the structure for which heat is provided. South facing windows, for example, serve as apertures through which solar energy is admitted to the building, and thermal storage may be provided by inherent structural mass. Solar radiation absorbed inside the building is converted to heat, part of which meets the current heating load whereas the remainder is stored in the structural mass for later use after the sunset. The objective of the work is to design a direct gain passive solar heating system with simplicity and low cost management.

1.3 Scope of the Work

Passive solar design uses sunlight to create energy efficient living and work spaces that are a pleasure to be in, and minimizes the use of fossil fuels and associated pollution. To top it all off, the principles of passive solar design are easy to grasp and implement in new construction. The purpose of these procedures is to make the results of recent scientific research on passive solar energy accessible to professionals involved in building design or design evaluation. By so doing, this new technology can be transferred from the research laboratory to the drawing board and the construction site.

2. Literature Review

Direct Gain Passive Solar Heating System

A direct gain passive solar heating system admits sunlight directly into the space to be heated through windows or other glazed apertures as indicated schematically in the Figure 1. The interior materials of the building are capable of absorbing large amounts of energy through radiation and convection [2].

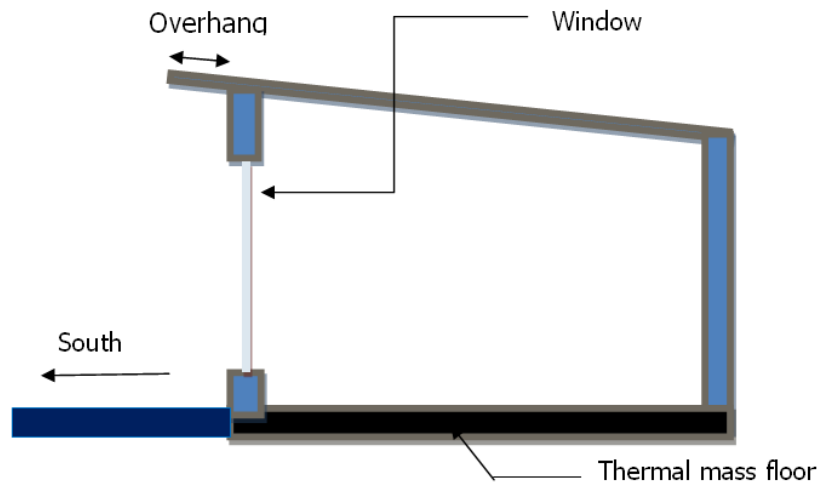

Figure 1: Schematic of Direct Gain Passive Solar Heating System

Elements of Direct Gain Passive Solar Heating System:

1. Aperture (Window)
2. Control (Overhang)
3. Thermal mass floor

- Distribution.

Factors Important for Direct Gain Passive Solar Heating System:

- Building orientation
- Window location
- Solar window & calculated roof overhangs
- Heat transfer mechanism.

3. Design of Direct Gain Passive Solar Heating System

3.1 Design of Direct Gain Window

In a direct gain passive system the window and the room are in effect, a vertical south facing flat plate collector with thermal capacitance. The methods for estimating radiation incident on a shaded surface are modified to account for transmittance of the glazing and absorptance of the room to estimate direct gains. Loss coefficients are in principle very similar to those of flat plate collectors. But the use of movable insulation must be taken into account. The monthly average net gain or loss from a direct gain system can be estimated by considering the solar gain into the rooms independently of the thermal losses through the window [1].

Net energy gain

The average daily radiation absorbed in the room can be written as:

$$Q_{s, r} = A_w \bar{I}_t \tau_g \rho$$

The average thermal losses for a day:

$$Q_{l, r} = U_w A_w (T_i - T_a)$$

The net energy gain:

$$Q_{net} = A_w \bar{I}_t \tau_g \rho - U_w A_w (T_i - T_a)$$

For December

$$Q_{net} = 1.5 \times 19.44 \times 0.85 \times 0.2 - 1.5 \times 1.25 \times (18 - 10)$$

For $w=1$, $e=0$, $g=0.2$ and $\bar{f}_i = 0.95$,

$$F_{r-s} = 0.35, \rho = 0.2,$$

For single glazing window

$$U_w = 6.7 \text{ W/m}^2\text{K}$$

Let, $T_i - T_a = 10^\circ\text{C}$

Now from equation (1)

$$Q_{net} = A_w (19.44 \times 0.85 \times 0.2 - 1.25 \times 10)$$

$$= 9.75 A_w$$

For, $A_w = 1.5 \text{ m}^2$

3

$$Q_{net} = 14.63 \text{ MJ per day for the month.}$$

For, $A_w = 1.25 \text{ m}^2$

$$Q_{net} = 12.19 \text{ MJ per day for the month.}$$

For, $A_w = 1 \text{ m}^2$

$$Q_{net} = 9.75 \text{ MJ per day for the month.}$$

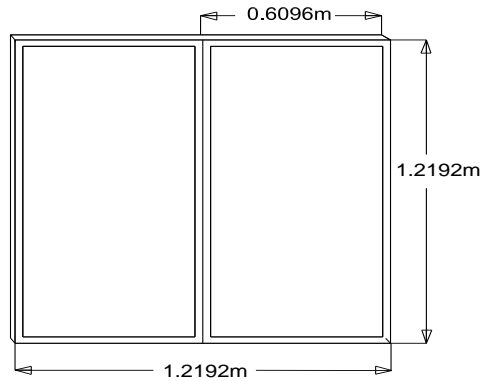

Figure 2: Aperture Area for Proposed Solar Gain System

3.2 Design of Thermal Mass

1. Should be located in the same space that has the direct gain system.
2. Optimum location is on floor directly behind glazed area.
3. A uniform distribution of thermal storage mass is conducive to a thermally uniform living space.

As a general rule, a massive surface in the direct zone should be relatively dark in color and a low-mass surface should be relatively light in color. This encourages absorption of sunlight on surfaces where heat can be stored [4].

For $A_g = 1.5m^2$

Floor area or thermal mass area ~~$A_g = 3A_g = 4.5m^2$~~

For $A_g = 1.25m^2$

Floor area or thermal mass area ~~$A_g = 3A_g = 3.75m^2$~~

For $A_g = 1.0m^2$

Floor area or thermal mass area ~~$A_g = 3A_g = 3m^2$~~

4

Thermal Mass: 2–8 inches of concrete, stone, adobe, etc

Insulation: 2 inches closed cell foam

Base: 4–6 inches of compacted gravel or sand

3.3 Sizing Overhangs

Sizing overhangs is a design that provides adequate protection from overheating in the fall may tend to reduce the amount of solar energy available for needed space heating in late winter or spring. Since an overhang does not provide protection from sky diffuse or ground reflected radiation, it is often necessary to provide additional countermeasures to prevent overheating during the cooling season. For this reason, the currently accepted design practice is to size an overhang such that the performance of the passive heating system is minimally affected, and employ additional countermeasures against overheating as required. The sizing procedure introduced [8]. After determining the last month for which total illumination of the aperture will be allowed, it is an easy matter to fix the overhang geometry. The overhang length is denoted by X and the separation is given by Y, as indicated in Figure 3. The ratio X/Y is related to the latitude (L) minus the declination (D) and this relationship is represented graphically in Figure 4 [8].

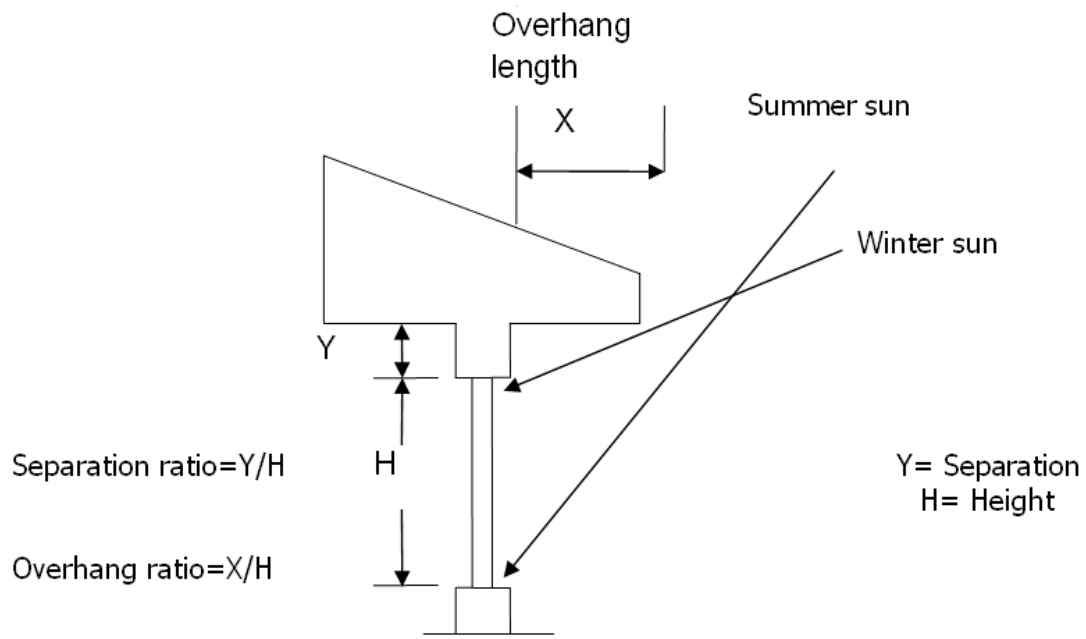

Figure 3: Overhang Geometry

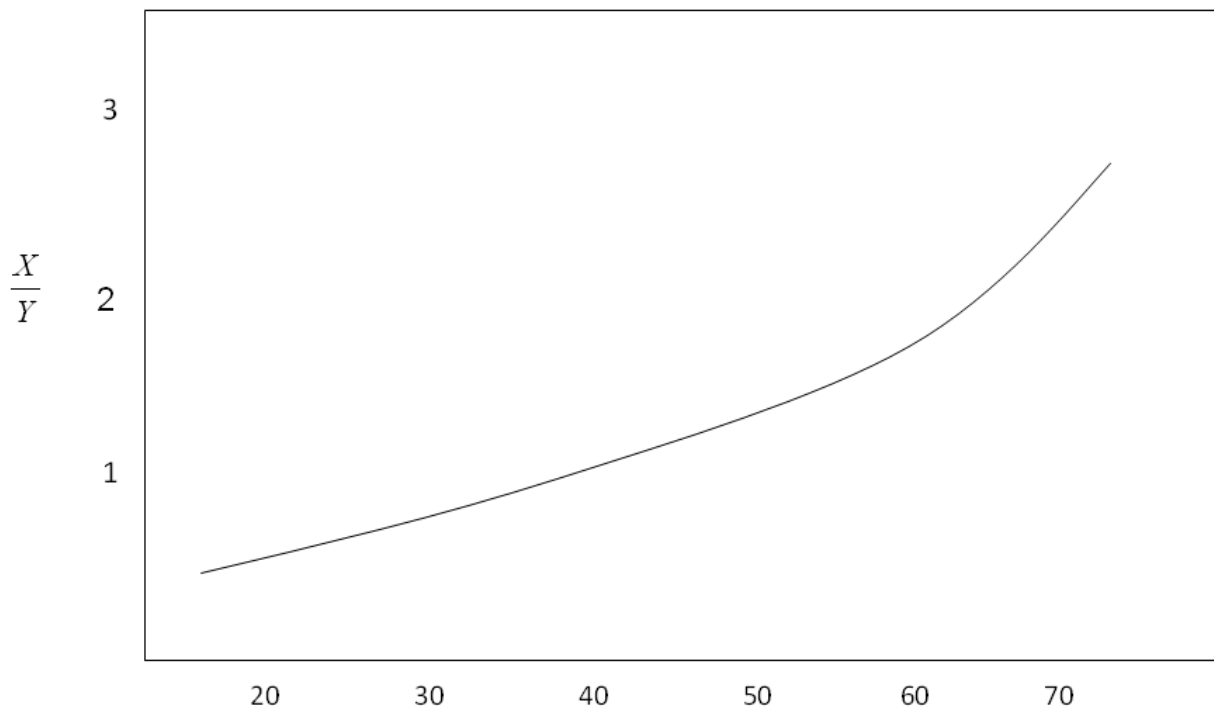

Figure 4: Ratio X/Y Related to (Latitude-Declination)

4. Conclusion and Recommendation

4.1 Conclusion

The design is based on low cost analysis in direct gain passive solar heating system for supporting developing countries. The few temperature difference between room and ambient is taken to be beneficial in cost for model passive building. The way of sizing overhangs is really a new era of simple and effective engineering world.

4.2 Recommendation

In direct gain heating system the length of the north side walls should be larger than east or west side walls so that larger portion of the thermal mass directly exposed to the sun and more energy can be absorbed by the thermal mass. Night insulation should be provided to reduce heat loss through the window. Double glazed aperture can also be provided to reduce heat loss through the window. Black tile can be used as absorber plate to increase absorptance of the surface as well as to increase net energy gain by the room. Better performance may be obtained by providing proper insulation.

References

1. John A. Duffie and William A Beckman, Solar Engineering of thermal processes, John Wiley & sons, New York.
2. Willam C. Dickison and Paul N. Cheremisinoff, Solar Energy Technology Handbook (part-B).
3. G.N Tiwari, Solar Energy, Narosa publishing house, New Delhi.
4. John D. Myers, Solar Application in Industry and Commerce, Prentice–Hall Series in Energy.
5. Frank Kerith and Jan F. Kreider, Principle of Solar Engineering, Hemisphere Publishing Corporation, Washington, London.
6. Renewable energy network, Local government engineering department (LGED), Bangladesh
7. www.sunplans.com
8. Unified Facilities Criteria (UFC), Department of Defense, USA.
9. Arizona Solar Center (AZSC)
10. Department of Energy (USA)