

Simulation of an Interdependent Metro-Bus Transit System to Analyze Bus Schedules from Passenger Perspective

Golam Mohammad M. Aurup and Ting Ting Cai
Department of Mechanical & Industrial Engineering
Concordia University, Montreal, Quebec, H3G1M8, Canada

Abstract

Simulation has been a very important tool in scheduling rapid transit systems (metro). We took an interdependent transit system comprising of metro and bus and looked at the existing bus schedule from passenger-experience perspective. Passenger experience of metro users is described by typical waiting time. For buses, user satisfaction of commuters depends mainly on waiting time in queues and length of queue. Also commuters get dissatisfied when they wait in queue and yet fail to take the bus and have to wait for the next bus. In this paper, at different metro stations, fixed schedule metro and bus arrival is simulated and field data of passenger arrival is added to that. Average waiting time for each bus is observed in this regard. A bus schedule is changed here and the effect of the change on the waiting time also is observed. Following this practice, feasibility studies for new bus schedule can be carried out to obtain certain levels of user satisfaction. Three stations from the Montreal Metro system are taken for this purpose. The system is simulated with simulation software Arena.

Keywords

Simulation, transit system, passenger experience

1. Introduction

Simulation is an important tool to create, maintain and optimize transport system schedules. Reports of such simulation are observed in Proceedings of Simulation Conferences [1-3]. Later some authors started to consider passenger experience while using simulation for the purpose of scheduling. They mentioned typical waiting time and typical traveling time as the passenger's expectation in metro services and suggested ways to restore them during scheduling the services [4-5]. The scheduling of interdependent metro-bus transit system is an interesting topic while high frequency metro service supports less frequent bus services. This paper looks into the issue with a simplified approach and proposes a framework for adjusting bus schedules to improve commuter experience. Theories and guidelines to treat the Simulation are mainly taken from books from Averill and Kelton [6-7]. Overview of simulation theories and model verification are consulted in more recent reports from the conference [9-10]. Simulation software Arena and its Input and Output Analyzers are used to model, run and analyze the transit system simulation and passenger experience.

1.1 Objective

The study simulated an interdependent transit system comprising metro and bus and added real passenger arrival information to that. The metro and bus systems run on static schedules and given the schedules are maintained, it is possible to figure out whether passenger expectations are met in terms of waiting time and queues. Passenger arrival is a complex phenomena and a simple station based passenger arrival approach is proposed. In this paper passenger and transit system interaction at three metro stations and corresponding buses are simulated. In results analysis stage, one bus schedule is changed and its effect on passenger experience is observed.

2. Methodology

The simulation proposed station based analysis of transit system and passenger arrivals. Here, passenger arrival of metro/bus does not affect adjacent stations. Probability distributions are made from time intervals of metro or bus arrivals and frequency of passenger arrivals. Three entities named 'metro', 'bus' and 'away' are used to generate passenger arrivals/departures. Events like passenger arrival, walking, waiting in queue and boarding are considered between metro and buses and away.

2.1 Simulation Platform

Simulation software Arena, version 7.01.00, Rockwell Software, Copyright © 2002-2003, is used to model the simulation. The Input and Process Analyzers of the software are used to prepare inputs and analyze results. Dell Dimension 4600 Desktop PC with 2.4 GHz Pentium 4 Processor and 1 GB memory is used to run simulation.

2.2 Assumptions

- The simulation is based on passenger activities on isolated stations. Effects of adjacent bus/metro stoppages are not considered. Arrival of the metro at the three stations is sequenced.
- The capacity inside metro is considered elastic because people normally do not miss metro after waiting in line.
- Boarding into bus is simplified and availability of empty seats in bus is not considered.
- The splitting of Metro commuters into different bus routes are calculated by proposed estimates.

2.3 Activity Analysis of the Metro-Bus Interaction System

The system shows two different activities in commuters. People come by metro to specific stations and then use the bus to go some other place, and people come to the metro station by bus and then take the metro to go some place. The detailed activities within are described below

- From Metro to Bus:** The metro from both directions come at the station at different times and people get down. Then they walk towards the exit of the metro. From the exit of Metro Station, they may board a specific bus, or go away walking or by car.
- From Bus to Metro:** People get down from bus and get into the entry of Metro station or go away. Some people join them from 'away' (the majority of commuters). They walk towards the platforms and are split into two directions and board the metro when it arrives.

3. Model Development

3.1 Proposals to model development

Some probability distributions and estimates are made to simulate the transit system. They are metro and bus arrivals, passenger arrival, distribution of arrivals from metro to different buses, delays to walk from metro exit to platform, waiting queues for buses and distribution of people from bus towards metro. The three stations selected are Chalevoix (X), Guy-Concordia (Y) and Saint Laurent (Z). Metro arrival directions are Angrignon (A) and Honore Beaugrand (B). 'Metro', 'bus' and 'away' are the three entities which generate or take boarding of passengers.

3.2 Building Blocks for Model

The Arena building blocks used are Create, Waiting, Assign, Signal, Split, Hold, Delay and Dispose. The create entities are used for both metro platforms for each direction, bus stoppages at metro exit and 'away'.

3.3 Segments of Model

The model has two different parts; the individual metro-bus interdependent system centering different stations and the integration of the different stations.

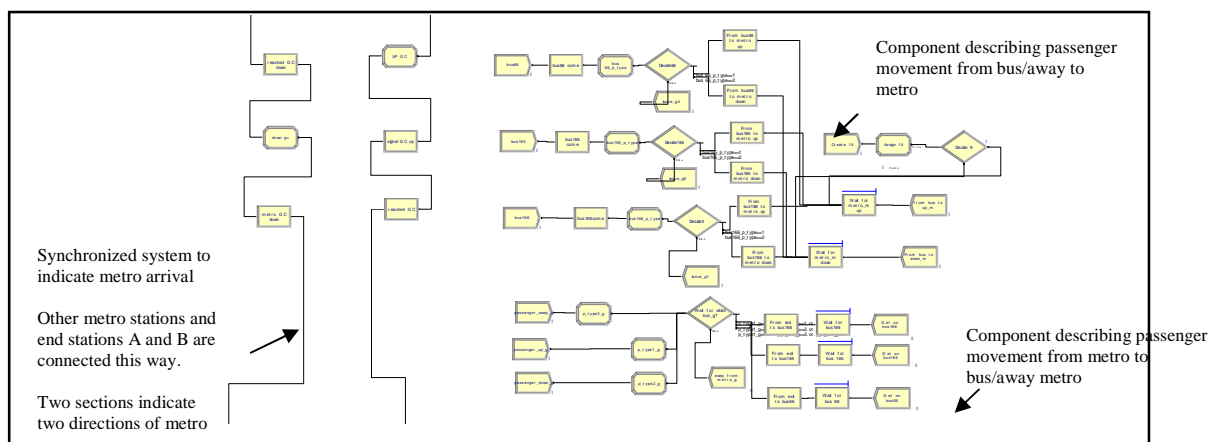

Figure 1: Arena Model for the transport system at station Guy-Concordia

3.3.1 Individual System Centering Metro Stations

a. Commuter Movement from Metro to Buses

When the Metro arrives, a signal is given to indicate arrival. People are created to come down from metro following a distribution. They are then assigned to split by a distribution to head towards the buses or 'away'. Then they are put in a delay using a distribution to reach the exit of Metro station. The people then either walk away to dispose or stay in queue. The queue is built with the hold. People are created from away and they share same queue. People are disposed (here it means they board the bus) following a distribution and this release is associated with the signal received after bus creation.

b. Commuter Movement from Buses to Metro

Buses arrive following a distribution from schedule. People are created with a distribution. A signal is placed to release People from Metro queue. People are assigned three types; going away and going metro direction A or B. People are also created to come from 'away' with a distribution. They are delayed to the metro stoppage. They are hold in queue until signal for metro arrival is received. They are disposed (here it is boarding the metro).

3.3.2 Integrated System Including Different Metro Stations

To build the integrated metro movement system, the Metros are created at A and B following the distributions of arrival. Then they are delayed with a distribution to reach the next station. A signal marks this metro arrival which is used by the Bus system. The arrival of people is assigned which integrates this metro movement with commuter movement of this Metro station. The other stations are integrated the same way and metro is disposed at the other end. This dispose shows how many metros are run in this line at run end.

3.4 Model Validation

The model validation was carried out while building the small segments. Each segment was run separately and was tested with values with known/calculable output. Related segments were run separately and results from the segments were compared. For example the metro arrival data was generated from probability distribution from metro time table. A full day's simulation showed the number of metros that arrived during the day. This was equal to the actual number of metro departures of a day. This validated that the metro arrival system was working properly. Passenger movement through the model was tested the same way by running the model over a known time and comparing results.

4. Data Collection and Analysis

4.1 Data Requirement Related to Metro or Bus arrival

Metro and bus schedules are required for the purpose. They are collected from transport authority. These data includes arrival intervals at different time segments of the day. These data is used in Arena Input Analyzer to make arrival distributions.

4.1.2 Commuter Related Data And Distributions

The distributions required to model the passenger arrivals are the following. This is required for each station and each bus route considered in our project.

- People get down from metro towards A
- People get down from metro towards B
- Distribution to split people into Bus routes and 'away'
- Distribution of people getting into Bus from Metro or away
- People getting down from each Bus
- Distribution for people from bus into A and B direction and away

To build the estimates the data were collected simultaneously at different points in the station.

- How many people get down from each metro to A
- How many people get down from each metro to B
- How many people get down from each bus and they head towards where (Metro or away)
- How many people get in each bus and from where (Metro or away)

4.2 Data Collection

Data was collected in the three stations for two hours. One hour of rush hour and one hour of non rush hour data. The distributions are prepared with these two sets of data.

5. Model run and Result Analysis

5.1 Run Criteria

The model was run for 5 days and 2 replications. 5 days was selected as the 5 weekdays show similar activities in the stations. Metro, bus and passenger arrival data on weekends are different and hence not considered in run. Result showed waiting time at different bus stoppage and metro platforms. Result for Bus 66 was picked and result analysis was continued.

5.2 Result Analysis

After running the model once successfully, the output data was analyzed to make the improvement. As the simulation was run for 5 am and to 00:30 am next morning, it is a terminating simulation. The confidence interval for the result was calculated. For statistic collected, waiting time for each bus and metro was found. The model was run for two replications. It was obvious that, to reduce the half width of the confidence interval on expected waiting time of each bus, the sample size was to be increased. Here, Bus 66 from metro B was taken for further analysis. Table 1 has data from run results.

Table 1: Running result from two replications of model

Replications	Average waiting time	Half Width
1	11.836	0.97521
2	12.302	1.2406

From the two replications above, $\bar{X} = 12.069$ and a sample standard deviation $s = 0.3295$, so the half width of the 95% confidence interval was calculated with the equation

$$\begin{aligned}
 & t_{n-1, \alpha/2} \frac{s}{\sqrt{n}} & (1) \\
 & = 12.7062 \times \frac{0.3295}{\sqrt{2}} \\
 & = 2.9605
 \end{aligned}$$

To reduce the half width from 2.9605 to 1.5, the following function was used

$$\begin{aligned}
 n & \cong n_0 \frac{h_0^2}{h^2} & (2) \\
 & = 2 \times 12.069^2 / 1.5^2 \\
 & = 5.6731
 \end{aligned}$$

Following the results, 6 replications was then taken instead of the two originally made and analysis was continued.

5.3 Output Analysis for bus 66

To reduce the passenger waiting time, bus frequency was increased. The probability distribution of bus arrivals was changed in the model. The frequencies of bus 66 and 661 are given in table 2. Instead of varied intervals from 23 minutes to 33 minutes, buses are sent at 28 minutes throughout the day. After that, new output was obtained for the new schedule. The second schedule was defined as bus 661. To compare these two alternative schedules, the Arena Output Analyzer was used to get the comparison.

The 'Paired-T means comparison' analysis was run with Arena output analyzer. The results are shown in table 3. The Output Analyzer does the subtraction of the means in the direction A-B, A for bus 66 and B for bus 661. The waiting time of old schedule for bus 66 was found larger than 661, difference from results 0.015 is found positive. This information supports that with increase in bus frequency, waiting time for passenger can be reduced.

Table 2: Frequency data for bus 66 and 661

Bus 66		Bus 661	
Interval (minutes)	Frequency	Interval (minutes)	Frequency
31	2	28	40
30	13		
29	3		
28	2		
26	4		
23	4		
33	10		
Total number of trips a day= 38		Total number of trips a day= 40	
Average of interval times= 29.5 minutes		Average of interval times= 28 minutes	

Table 3: Paired-T Means Comparison

Identifier	Estd. Mean Difference	Standard Deviation	0.950 c.i. Half-width	Minimum Value	Maximum Value	Number of Observations
Wait for 661	0.015	1.2	0.0884	0	15.2	712
				0	13.3	712
Fail to reject $H_0 \Rightarrow$ means are equal at 0.05 level						

6. Conclusion

The study was part of a class room project. It was found that the proposed data collection techniques to simulate accurate passenger arrival require a lot of manpower and time which only the transport authorities are capable to generate. So, collected data was a little inadequate to represent the entire day's simulation. Another important issue is that frequency distributions from metro/bus time table were made to simulate the arrivals. This approach holds possibility to mix rush hour passenger arrivals with the off-pick hour metro/ bus arrivals. A solution to this issue might be scheduling the metro or bus arrivals than generating random arrival times. Passenger arrivals vary largely with hour of the day, so does the arrival of metro or bus; use of fixed schedule metro/bus arrival and different passenger arrival distributions for different time of day seem capable to improve the results. This type of metro or bus arrival also can be achieved by Arena built in scheduling tools. Some results in this study showed high levels of error which might be a result of mixing of peak and off peak transport and passenger arrival rates. Comparison of results from these two approaches would be very interesting extension of this work.

Every station on each weekday/weekend shows very different patterns of passenger arrival. So distributions to simulate passenger on each day should be taken from several data of same day. A run should last at least one week to get the 'real replication'. For this reason provisions need to be provided in the model so that it can use 7 different 'input' sets for a complete run of one week. Break downs may be added to the system also. It was seen as expected that increased frequency of buses reduces waiting time of passengers. But additional operating cost is required for this change in bus schedule to achieve targeted service improvement. Optimization of passenger experience and bus scheduling can be another interesting extension of the study.

Acknowledgements

The study was carried as part of a class room project of the course 'Discrete System Simulation' in the Department of Mechanical and Industrial Engineering, Concordia University, Montreal, Quebec, Canada. The authors are thankful to the course instructor, Dr. Ali Akgunduz, for his encouragement and suggestions and idea to simulate the interdependent metro-bus transit system.

References

1. Martin, P., "Train Performance and simulation", Proceeding of Winter Simulation Conference, 1999.
2. Brill, J.C., and Whitney, D.E., "Development and application of an inter-modal mass transit simulation with detailed traffic modeling", Proceedings of Winter Simulation Conference, 1997.
3. Brunner, D., Cross, G., McGhee, C., Levis, J., and Whitney, D., "Towards increased use of simulation in transportation", Proceedings of Winter Simulation Conference, 1997.
4. Goodman, C.J., and Murata, S., "Metro traffic regulation from passenger perspective", Proc Instn Mech Engrs Vol 215, 2001.
5. Goodman, C.J., and Murata, S., "Optimally regulating disturbed metro traffic with passenger inconvenience in mind", International conference on Developments in Mass Transit Systems, 20-23 April 1998.
6. Law, A. M., and Kelton, W. D., "Simulation Modeling and Analysis", 4th Edition, McGraw Hill Book Corporation, 2007.
7. Kelton, W. D., Sadowski, R. P., and Sturrock, D. T., "Simulation with Arena", McGraw hill Book Corporation, 2004.
8. Aurup, G.M.M., Cai, T.T., Hakimi, S., "Simulating the Métro and Autobus System in Montréal with Arena", Project Report, Discrete System Simulation, Department of Mechanical and Industrial Engineering, Concordia University, Winter 2008.
9. Sergeant, R. G., "Verification and validation of simulation models", Proceedings of the 2007 Winter Simulation Conference, 2007.
10. Goldsman, David, "Introduction to simulation", Proceedings of the 2007 Winter Simulation Conference, 2007.
11. Ballis, A., Liberis K., and Moschovou T., "Investigating the capacity of a metro line by means of a simulation model", Proc. Instn Mech. Engrs Vol. 218 Part F: J Rail and Rapid Transit, 2004.